

VEHICLE DIAGNOSTIC AND TRACKING USING ANDROID

Prof. S. A. Deshpande, Varad Lanke, Akshay Lanke, Pratik Ayachit
Dept. of Comp & IT
PVG's COET, Pune University
Pune, Maharashtra, India

Abstract—This system aims to provide monitoring and tracking a vehicle's performance by communicating the obtained data to a mobile device via Bluetooth at very low cost. Then the results are visible to the user to monitor data like fuel level and other vehicle electromechanical parameters. Data collected sent to the server which is accessed by owner to monitor the system. This is finished by live readings gathered from different sensors on-board diagnostics system(OBD).The cell phone transmits information to the server utilizing cell web association. This paper exhibits the outline and usage of a venture that adventures Bluetooth abilities in cell phones running the Android Operating System to speak remotely with an inserted framework.

Keywords-Bluetooth, Microcontroller, Android, Wireless Communication, Database, Threshold Values

I. INTRODUCTION

As of late, Smartphone's have gotten to be numerous individuals essential individualized computing gadget because of their boundless abilities, versatility, and minimal effort. Worked in car route frameworks are being outfitted with different sight and sound capacities to fulfill the client desires of advanced capacities and components and offer various administrations in the current incredibly focused business sector state. This considers the general framework cost and confines the focal points to top of the line vehicle models. This paper shows an outline and technique for execution that sets up a Bluetooth association between an inserted framework and a Smartphone running an Android working framework (OS). The outline is perfect for applications that require ongoing observing of information and imparting the deliberate values immediately. As of late, the issue of determinations of deformities and flaws on a remote vehicle has gotten extensive consideration.

Now a days the taxis are in expanding request. This framework is helpful for taxicab proprietors to track and analyze vehicle like checking of fuel level, temperature level

and give data about safety belt, touch, place at which mischance happened. We introduce in this paper a minimal effort, streamlined, yet flexible vehicle symptomatic framework that is perfect with all vehicles. We have picked an advanced cell as the processing gadget for the conspicuous development and interest on such cell phones, notwithstanding decreasing the general framework cost by using the implicit functionalities that is coordinated in such minimal gadgets. Likewise, when introduced appropriately, such gadgets can be an ease different option for incorporated route frameworks. An Android application was created to peruse and show this information continuously. The Android OS is the quickest developing OS on the portable business sector. Besides, it is open source; in this manner permitting more simplicity and flexibility when creating applications.

1.1. System Overview

The purpose of our vehicle tracking and diagnose system by exploiting the Smartphone's wireless capabilities, a user is then able to control various other devices and monitor a wide array of sensors remotely.

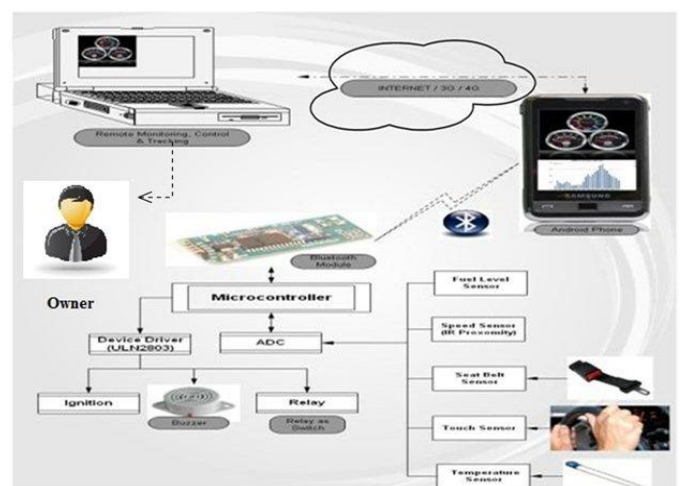

Fig.1.Vehicle Diagnostic Tool using Android



The fig.1 shows the vehicle diagnostic tool using Android. As shown in the figure various sensors are connected to the ADC which collect the data. Then send this data to the Android device by microcontroller via Bluetooth. Android device checks current values with threshold values and send back to microcontroller .If any sensor value differs with the threshold value then it will be indicated by the ULN (i.e Device Driver) for alert purpose using buzzer or vibration. The Android app shows the real time data. The data send to the server stored in database and user is able to monitor real time data.

1.2 Challenges of the system

1.2.1 Interfacing between Microcontroller and Android device via Bluetooth

The interfacing between Microcontroller and Android device via Bluetooth is one of the major challenges. We are using MAX 232IC for serial communication.BT HC-05as a Bluetooth transceiver module that has an approximate range of 100 meters. The Bluetooth module is configured as a Slave and the mobile phone is considered to be functioning as a Master. The microcontroller sends/gets information to/from the Bluetooth module, which transmits/gets information ceaselessly. Consequently for correspondence microcontroller and android gadget must be interfaced properly.

1.2.2 Network Connectivity Issues

The android device sends data to the server using cellular internet connection. The challenge is if vehicle is in the hilly region where no network is available then data can't be send to the server and hence not able to see various parameters of the vehicle.

1.2.3 Maintenance of Sensors and Devices

Sensors plays very important role to produce the output. If any sensor not working properly then user not getting perfect information about vehicle like temperature condition etc.

1.3. Applications of Diagnostic and Tracking System

This system is mainly useful for the cab owner. Where owner can monitor and view the parameter of the vehicle. If accident happen then alert is send to the owner by SMS, and as the GPS is enabled it is possible to know the location of the vehicle. Other applications of the system where it can be used are as follows-

- Cab System
- Public Transport System

II. EXISTING SYSTEM FOR TRACKING AND DIAGNOSTIC

GPS and GSM

A vehicle following framework joins the establishment of an electronic gadget in a vehicle, or armada of vehicles, with

reason planned PC programming at any rate at one operational base to empower the proprietor or an outsider to track the vehicle's area, gathering information in the process from the field and convey it to the base of operation. Cutting edge vehicle following frameworks generally utilize GPS or GLONASS innovation for finding the vehicle, however different sorts of programmed vehicle area innovation can likewise be utilized. Vehicle data can be seen on electronic maps through the Internet or particular programming. Vehicle following frameworks are likewise mainstream in buyer vehicles as a burglary counteractive action and recovery gadget. Police can basically take after the sign radiated by the following framework and find the stolen vehicle. At the point when utilized as a security framework, a Vehicle Tracking System might serve as either an expansion to or substitution for a conventional Car alert. Some vehicle following frameworks makes it conceivable to control vehicle remotely, including square entryways or motor if there should arise an occurrence of crisis. The presence of vehicle GPS beacon then can be utilized to decrease the protection cost.

TELEHEALTH APPLICATION

As a case, the upsides of this capacity in telehealth applications are various. Remote therapeutic checking permits patients to gather and view wellbeing related information while on the go ,enhancing the personal satisfaction of those approached to wear sensors for tests. This information is then effectively gotten to by social insurance suppliers, given that Smartphone's are effortlessly matched up with an online database that has a substance administration framework (CMS).This has demonstrated to lower medicinal services costs, enhance the nature of the consideration gave by offering 24 hour observing, and give access to those living stuck in an unfortunate situation setting out to healing centers and facilities.

Advantage: This framework is valuable for analysis.

Drawback: This framework is accessible in sumptuous autos such as BMW, Audi and so forth. The determination framework, it is immoderate as they are not executed on a solitary unit and it is not accessible effectively for others.

III. METHODOLOGY

3.1 Hardware Setup

The hardware setup is the vehicle unit .The dedicated and integrated hardware setup of the vehicle. It is very cost effective as the sensors are integrated. Hardware setup includes:

3.1.1 The AT89C51 Microcontroller

The AT89C51 microcontroller is a member of the 8051 family. The AT89C51 it is a Dual Input 40 pin microcontroller. The 89C51 microcontroller have four ports (i.e.P0,P1,P2,P3).The 89C51 is a UART (i.e. Universal



Asynchronous Receiver Transmitter).The AT89C51 is low power, high performance CMOS 8 bit microcomputer with 4k bytes of PEROM. 120 bytes of RAM, 32 I/O lines, 16 bit timer/counter .AT89C51 is powerful microcontroller to many embedded control applications.

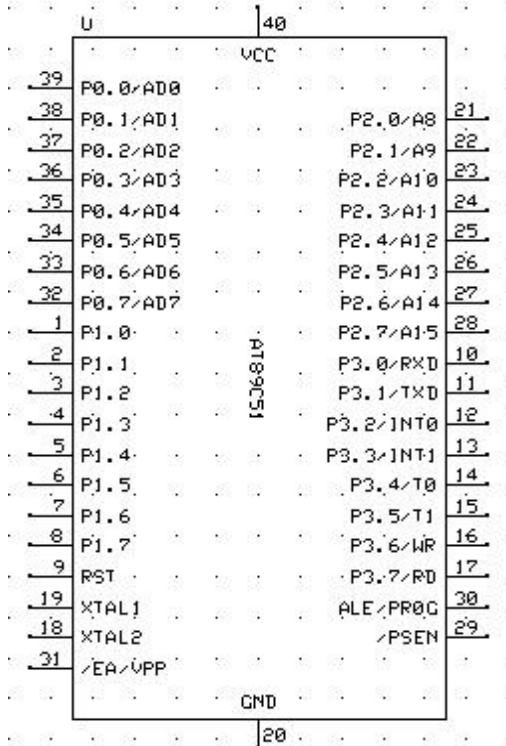

Fig. 2 . AT89C51

3.1.2 ADC 0808:

ADC 0808 it is 8 channel 8 bit converters. It takes Analog values and converts it into Digital values. The various sensors are connected to it as per our requirements are as follows:

3.1.3 ULN 2803:

ULN 2803 it is known as the Device Driver. The various devices connected to it are Buzzer, Vibration or Motor etc. for alert purpose. It requires VDD 12 volt. ULN 2803 have 8 I/P and 8 O/P pins.

3.2. Communication between Microcontroller and Android Device

Correspondence between Android Device and Microcontroller is by means of Bluetooth. Sensor status is seen at Android Device. For Bluetooth Transceiver the microcontroller is customized to send the estimations on its UART to the Bluetooth module. Bluetooth gives a way to associate gadgets,

for example, cell telephones over a safe, all around unlicensed short-go radio recurrence (2.45 GHz) and to empower the trading of data between them .We are utilizing MAX 232IC as a Bluetooth handset module, that has an inexact scope of 100 meters. The Bluetooth module is designed as a Slave and the

Sensor Name	Use
Level Sensor	This sensor is used to check Fuel level. In our task we are utilizing the potentiometer as the fuel level sensor.
Temperature Sensor	This sensor is used to check engine temperature level.
Touch Sensor	This sensor is used to detect the touch to the steering.
Seat Belt Sensor	This sensor is used to check whether seat belt is locked or unlocked. We are utilizing the basic mechanical switch as a seat belt sensor. In one sort of small scale switch, inside there are two conductive springs.
Alcohol Sensor	This sensor is used to check alcohol consumption.
Speed Sensor	This sensor is used to alerting when speed limit exceeds.
Accident Sensor	This sensor alert when there is chances of vehicle crashing or when vehicle is crashed it send notification to the owner.

cell telephone is thought to be working as a Master.

Table -1 List of Sensors

The microcontroller sends/gets information to/from the Bluetooth module, which transmits/gets information constantly. Bluetooth utilizes a radio innovation called recurrence jumping spread range, where information transmitted is hacked into lumps, which are transmitted on up to 79 groups, each with a transmission capacity of 1 MHz focused from 2402MHz to 2480MHz. Bluetooth associations require an expert/slave relationship between customers, with the expert permitted to speak with up to 7 slaves. MAX 232IC require RS 232 convention in the event that it is not TTL perfect. MAX 232IC for serial correspondence. It requires 0-25V. It is utilized for association in the middle of microcontroller and android gadget.

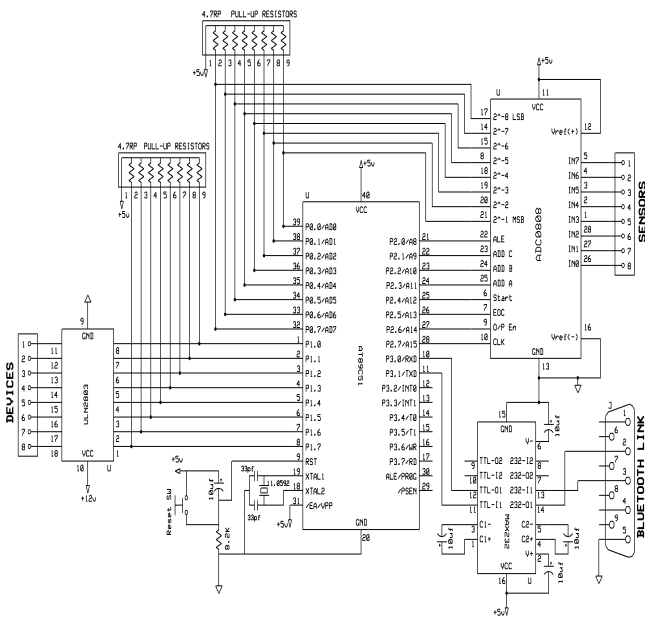

Fig. 3. Schematic Diagram

3.3 Android Application

Android is a working framework which depends on the JAVA programming dialect and keeps running on Linux portion. The Android stage is comprised of the working framework, middleware, client interface and application programming. Notwithstanding Android, there are a few distinctive working frameworks in the business sector for advanced cells, for example, Symbian, Windows Mobile, RIM, iPhone OS (iOS), ... and so forth. Android has four recognizing favorable circumstances when contrasted and the other cell telephone working frameworks: 1) It is an open portable stage; Users can alter and grow applications as indicated by their necessities. 2) All applications are equivalent, where all applications are keep running in virtual machine assets. 3) The application programs have no limits. The engineers can join the information of the World Wide Web and the locally accessible (put away) in the Android stage since Android can get to the center cell phones and Internet through the standard API. 4) The application advancement is fast and simple since the Android stage amplifies a lot of helpful libraries and devices to the designers. Our Android versatile application programming was intended to perform the accompanying errands: a) Connect to the Bluetooth module. b) Send ask for messages to the OBD framework. c) Receive reactions from OBD framework. d) Display the reactions to the client in an easy to understand structure (values in decimal). e) Be ready to transfer the qualities to a remote server.

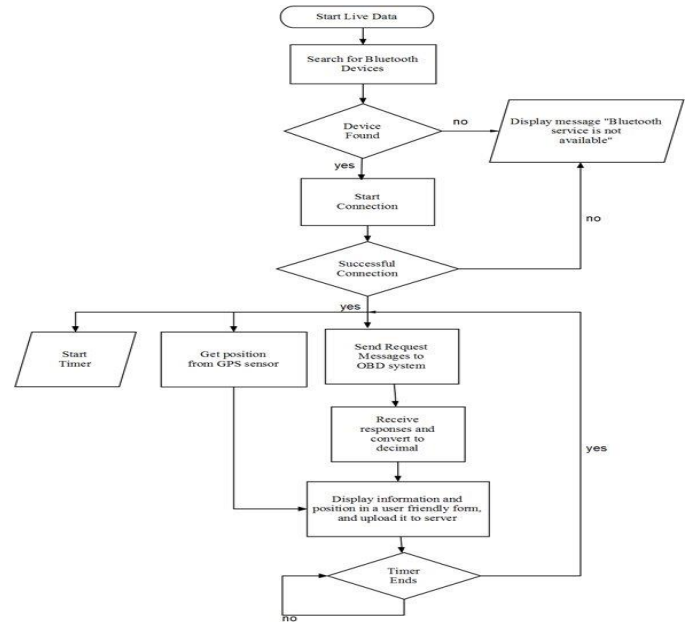

Fig. 4. Android Application Flowchart

We have added to our Android portable application programming on a Windows® 7 stage for an Android 2.2 or more. We introduced improvement environment readiness programming which incorporated the java advancement pack (JDK), Eclipse, Android programming advancement unit (SDK). In the interim, an Android improvement device (ADT) is the module through which Eclipse is altered for Android applications advancement. It gives an intense coordinated environment furthermore, develops the elements of Eclipse that permits clients to make applications rapidly and include segments the API. Since the telephone is matched with the devoted pack, it turns into the obligation of our application to set up the correspondence station and start the accepting of information. Here, the telephone ought to be associated with the device [1][4].

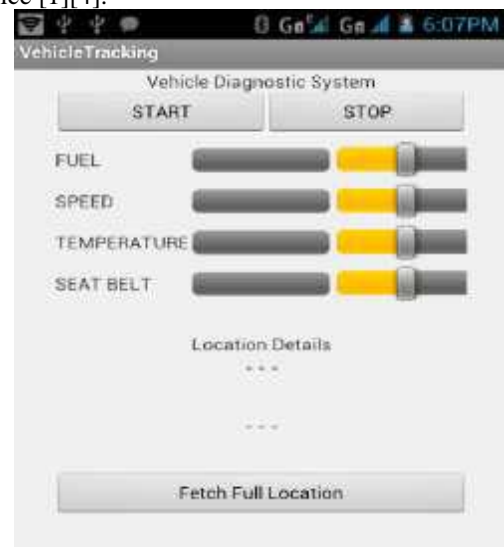

Fig. 5. Configuration menu on the mobile application

3.4 Setting of Threshold Values:

The Threshold Values are set by the Admin. The Threshold Values are checked at the Android Device. If Threshold Values doesn't satisfy its requirement then it is informed by the Buzzer, Vibration or SMS notification.

3.5 Server and Administrator Management

The Android gadget sends information to the server by means of cell web association. The server stores this information as the database. Administrator/User can get to the database. At that point the Admin/server can see the parameter and screen the framework. The server needs to get ongoing information, henceforth, the application at the cell phone needs a high information rate broadband association, for example, that upheld by 3G cell Internet. Server that contains a MY SQL database and web administrations like SOAP/XML .The server gets the readings as HTTP/TCP bundles. The server ought to have a static open IP location to which the application bundles are ordained. The portable application exchanges information by means of cell web from the coordinated OBD framework. Overseer can see the accessing so as to ongoing parameter values the database and keep up the framework.

We depict in Fig. 6. The implementation of a simple diagnostic system. As shown in above architecture it consist of two parts one is software part and second is hardware part. Software part consists of admin, server and database. Hardware parts consist of microcontroller; sensors and devices are connected to microcontroller. The enabled GPS in Smartphone is used for tracking. The various sensors like Fuel level, Temperature ,Touch ,Seatbelt ,Accident collect the values which are in analog form convert it into digital form. Then this value sends to the Android device via Bluetooth, where Android device compare collected values with the threshold values. Then Android device transmit those values to the microcontroller. If the threshold values are crossed then it is indicated by the buzzer, vibration or through SMS alert. Then this data is send to the Central server through an Android device by using cellular network connection. In Central server the data is stored in the form of the database. The database is stored in a server like glassfish server. The Admin accesses the database and view various parameters. Maintenance of sensors should be regularly done by the Admin.

V. CONCLUSION

We executed an all-inclusive coordinated framework which is made out of a blend of an easy to understand Android-based portable application programming and a minimal effort equipment unit used to make an on-board vehicle analytic framework. The portable application programming will connect with the equipment interface unit remotely by means of Bluetooth to gain craved vehicle parameters. These readings are send to the server by means of a cell web association. The information put away in database at the server, then administrator can get to the database and perspective the parameters. Due to a wide assortment of reasonable applications and numerous testing research issues, it has been an extremely dynamic exploration range lately.

IV. PROPOSED SYSTEM

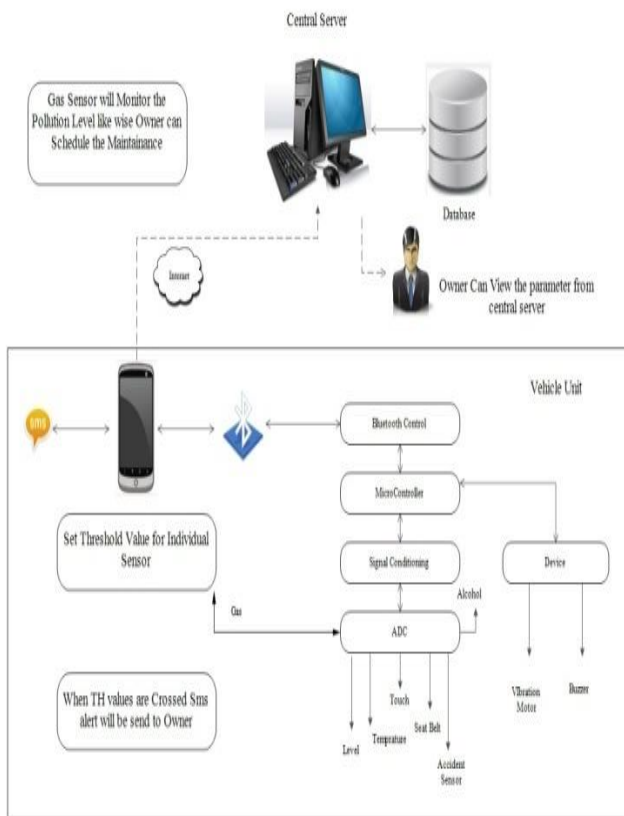

Fig. 6 . Architecture diagram of the system

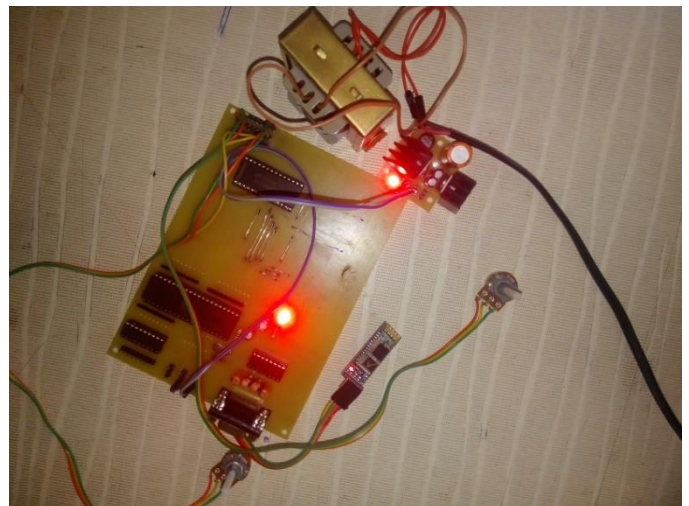

Fig. 7 .The PCB and other hardware installed in the vehicle.



VI. REFERENCE

- [1] Ashraf Tahat, Ahmad Said, Fouad Jaouni, Waleed Qadamani, "Android-Based Universal Vehicle Diagnostic and Tracking System", IEEE 16th international symposium, 2012.
- [2] M. Johanson, and L. Karlsson, "Improving vehicle diagnostics through wireless data collection and statistical analysis," IEEE Vehicular Technology Conference (VTC-Fall 2007), pp. 2184-2188, September 2007.
- [3] Jianping Cai; JianZhong Wu; Minghui Wu; MeiMei Huo; , "A Bluetooth toy car control realization by android equipment," Transportation, Mechanical, and Electrical Engineering (TMEE), 2011 International Conference on , vol., no., pp.2429-2432, 16-18 Dec. 2011.
- [4] Samer hawayek, claude Hargrove, Nabilabousaba "Real-Time Bluetooth Communication Between an FPGA Based Embedded System and an Android Phone".
- [5] L. Ferhatovic, A. Lipjankic, A. Handzic, and N. Nosovic, "System for remote diagnostic of vehicle defects," in Proc. 17th Telecommunications Forum (TELFOR), pp. 1323-1326, November 2009.
- [6] Nilesh Ananthanarayanan, "Intelligent Vehicle Monitoring System using Wireless Communication", 2011.
- [7] Baburao Kodavati, V.K.Raju, S.Srinivasa Rao, A.V.Prabu, T.Appa Rao, Dr.Y.V.Narayana "GSM AND GPS BASED VEHICLE LOCATION AND TRACKING SYSTEM"/ International Journal of Engineering Research and Applications, ISSN: 2248-9622, Vol. 1, Issue 3, pp.616-625
- [8] Martel, M. Normand. "Remote medical monitoring system", US Patent 2006/0122469 A1, Nov 16, 2004.
- [9] A. Tahat, A. Sacca, Y. Kheetan, "Design of an integrated mobile system to measure blood-pressure," in Proc. IEEE 18th Symposium on Communications and Vehicular Technology (SCVT), pp. 1-6, November 2011.