



INTRODUCTORY STOCK MARKET DATA EXPLORATION AND ANALYSIS

Lokesh Kumar Shrivastav
Computer Science & Engineering, AMITY UNIVERSITY
Noida, Uttar Pradesh – 201303, India

ABSTRACT- The effect of periodic time dependence in interest rate of stock price movement is investigated. The model is based on Black – Scholes SDE time – dependent rate, whole solution is governed by lognormal process. The striking price is modeled as FPT and its behavior is analyzed by carrying out extensive Monte Carlo simulation of SDE. A new phenomenon of damped oscillatory behavior of FPT is predicted.

I. INTRODUCTION

The understanding of the stochastic dynamics of stock price is a challenging problem. During the past decades many sophisticated mathematical and computational techniques have been developed for analyzing financial markets. Many aspects related to this problem cannot be solved analytically and one has to resort to extensive simulation studies. This gave the birth of a new field called as computational finance, which requires development of computational algorithms. The solution of PDE and Monte-Carlo simulation enable us to study different aspects of financial derivatives and analysis of portfolio risks [1-5]. Monte Carlo Method is a simulation technique, which makes use of random numbers. These numbers are independent and identically uniformly distributed. Earlier data was neither helping to predict the price of the stock in future nor explored the dynamics of stock price. Computational finance models attempt to capture the randomness of a stock's price moment in future. In a fixed future time, the change in stock's price is modeled as a random variable having a normal distribution. The standard deviation of the normal variation depends on the time duration as well as the volatility of the market. When the market becomes more volatile then we look further ahead, this mean, the less likely the stock will have a price near the adjusted current price [2].

II. MOTIVATION AND GOAL

The evolution of stock price is governed by stochastic differential equation, which is based on well-known Black-Scholes Model. A quantity of

interest to practitioners involves the computation of the expected pay-off function. Noting that the pay-off function is essentially a non-linear function, explicit time dependent result is not available. This has necessitated the need for development of computation algorithms. Most of the studies pertain to study of the first moment of discounted pay-off function. Our interest is to examine a more general question

regard of the stochastic evolution of this pay-off function. To this end, extensive simulation experiments have to be conducted to yield insight into pay-off function dynamics.

III. CALCULATION OF OPTION PRICING

Computational finance is a useful tool for determining the price of a financial 'derivative'. Derivatives are financial instruments which regulate agreements on transaction in future and can be classified as futures, forward, options [3] etc. The option pricing is the market price of the option contract. Option pricing theory is one of the pillars of finance and it has wide-range of applications. In this work, we have restricted ourselves to the study of options as a financial derivative. An option can be defined as the right to buy or sell a risky asset that may risky in future. However, there is no obligation on the part of option holder to enter into contract [1, 2].

Options are available for the limited time period. The Maturity Time T of every option is fixed i.e if $(t > T)$ the right of the option holder expires and the option is worthless. There are two basic types of options: calls and puts. A call option gives its holder the right to buy a specified number of the underlying asset by paying a specified exercise price or strike price (K). A put option gives its holder the right to sell a specified number of the underlying asset by paying a specified strike price. It is customary to denote the value of option by V which depends upon the stock S (in terms of price per share). Thus, one can write $V=V(S, t)$. Two widely used options are; American options and European options. American options can be exercisable at any time up to the expiration date, whereas European options can be exercised only at expiration date (T). In terms of payoff function, one can obtain option value for the holder [1-4].

- The holder of the option makes a profit if $S(T) > K$.
- The holder of the option does not make profit if $S(T) < K$.
- Thus the pay-off function is a non-linear function defined as

$$(S(T)-K)^+ = \text{Max} \{0, S(T)-K\}$$

Hence, the value of the European call option(C) at expiry date is given by

$$C = \text{max}(S(T)-K, 0)$$

and the value of the European put option(P) at the expiry date is given by

$$P = \text{max}(K-S(T), 0)$$

Shown in figures 1(a) and 2(b)

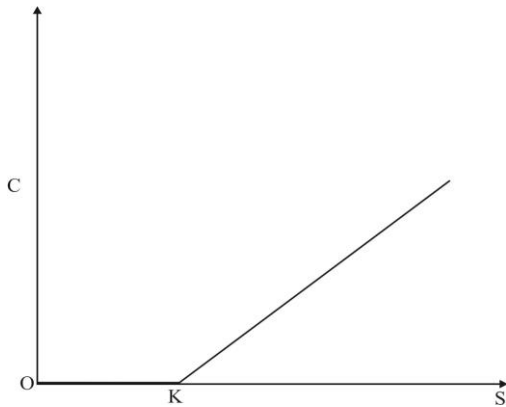

Fig1 (a): European call option

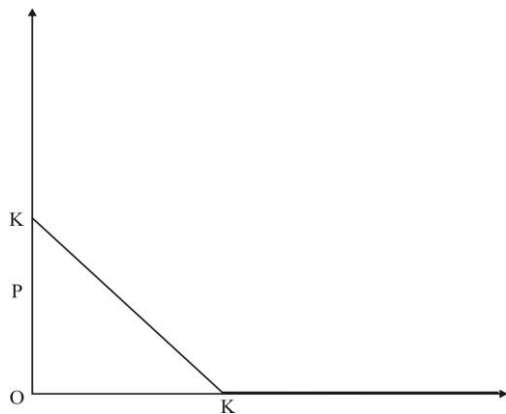

Fig1 (b): European put option

The value of an American option should always greater than that of a European option because American option includes the European type exercisable at $t=T$ and also include early exercise for $t < T$. i.e. American option \geq European option

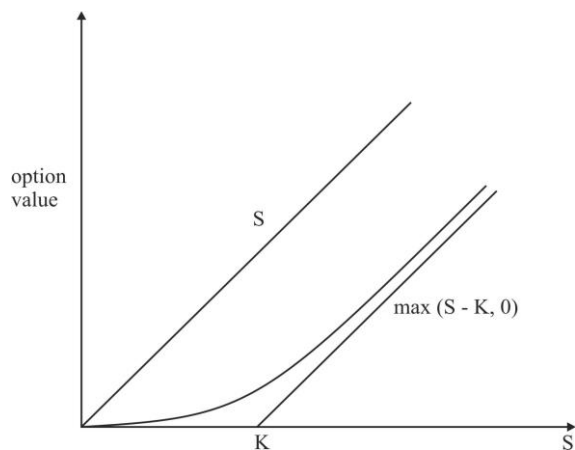

Fig1.2: The upper and lower bounds of option value

IV. THE OPTION PRICING MODELS

Option pricing modeling has been an active area of research in the past decades. The well-known models are:

1. The Binomial Option Pricing Model (BOPM).

2. Black Scholes Model.

We describe these models in some detail and closely follow the modeling formulation as given in [8, 13].

V. THE BINOMIAL OPTION PRICING MODEL (BOPM)

In the BOPM, time is discretized and represented in terms of periods. BOPM model, though not very realistic, is simple to implement. The model is based on the assumption that during a period there exist two states. The quantities of interest are: call value C , put value P , strike price K , stock price S and the dividend amount d .

To understand the probabilistic nature of stock prices, we consider that stock price S in a period can move either to state S_u or S_d with probabilities

$$p(S=S_u) = p, \quad p(S=S_d) = 1-p$$

This corresponds to Bernoulli distribution.

In terms of risk free interest R , we define $d < R = e^r < u$. Now S takes S_u and S_d with probabilities p and $1-p$ respectively.

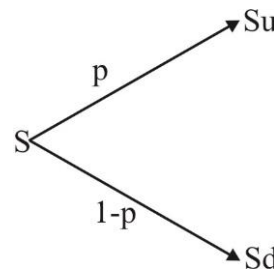

Fig 1.3(a): Binomial model for stock price

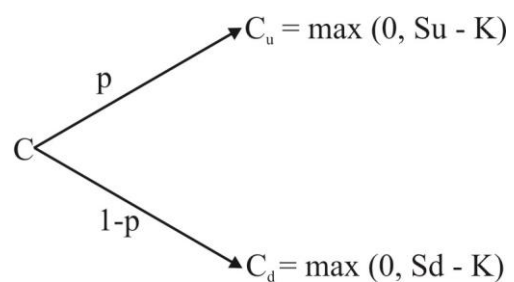

Fig1.3 (b): Value of one period call in BOPM

The expected stock price would be

$$PS_u + (1 - P) S_d = PuS_0 + (1 - P) d S_0$$

From the above Risk-Neutral Valuation:

$$Se^{r\Delta t} = pSu + (1 - p)Sd$$

$$\text{Or } e^{r\Delta t} = pu + (1 - p)d$$

where p is the risk-neutralised probability given by

$$p = \left(\frac{e^{r\Delta t} - d}{u - d} \right), \quad u = e^{\sigma\sqrt{\Delta t}} \text{ and } d = e^{-\sigma\sqrt{\Delta t}}$$

VI. PORTFOLIO EVALUATIONS

We now consider a portfolio where we have h shares of stock and B riskless bonds. The problem is to determine these values



We have

$$c_u = \text{Max}(0, Su - K) \quad (1.1)$$

$$c_d = \text{Max}(0, Sd - K) \quad (1.2)$$

such that

$$\left. \begin{aligned} hSu + RB &= c_u \\ hSd + RB &= c_d \end{aligned} \right\} \quad (1.3)$$

Solving the above equations we obtain

$$h = \frac{c_u - c_d}{Su - Sd}, \quad B = \frac{u c d - d c_u}{(u-d)R}$$

(See Fig.1.3 (b) for illustration.)

The importance of this formulation is that it enables us to obtain risk neutral valuation.

For details one may refer to [3, 14].

Binomial call option gives

$$C = [c_u p + c_d (1 - p)] e^{-r\Delta t}$$

Here C is the only current option value consistent with no-arbitrage opportunities; it is called an arbitrage value.

Binomial current put option gives

$$P = [p_u + p_d (1 - p)] e^{-r\Delta t}$$

VII. MULTI PERIOD OPTIONS CALCULATION

The foregoing analysis can be easily extended to multi period where one gets a Binomial tree. It is easy to see the rationale for getting Binomial type distributions. In a multi period one will deal with a sum of Bernoulli type of trials which again yields Binomial distribution. For details one may refer to [3]. The analysis enables us to derive the value C of European call. We find

$$C = \sum_{j=0}^n b(j; n, p) u^j e^{-rj} - K e^{-rn} \sum_{j=0}^n b(j; n, p) \quad (1.4)$$

Here $b(j; n, p)$ are binomial probabilities,

$$b(j; n, p) = \binom{n}{j} p^j (1-p)^{n-j}, \quad j=0, 1, \dots, n$$

$$\text{where, } p = \frac{e^{r\Delta t} - d}{u - d}$$

The computational aspects lead to development of Binomial tree algorithm [8].

One important issue concerns estimation of computational efficiency. It is important to note that one can recursively update Binomial probabilities by noting the following result

$$\frac{b(j; n, p)}{b(j-1; n, p)} = \frac{p(n-j+1)}{(1-p)j} \quad (1.5)$$

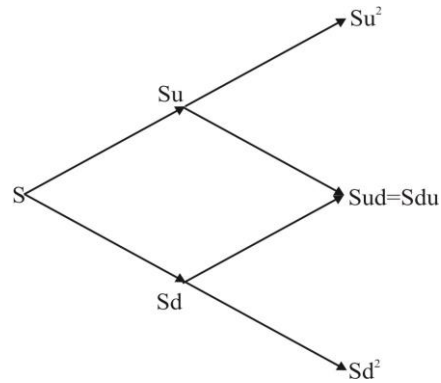

Fig 1.4: stock price with two periods

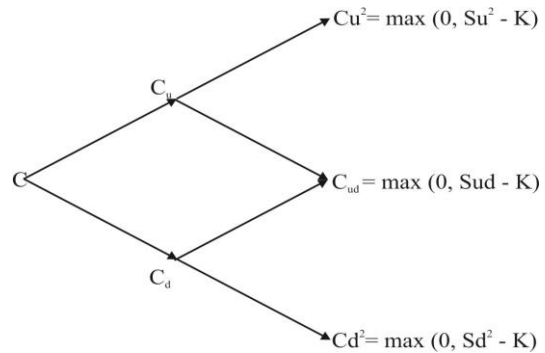

Fig 1.5: Value of a two-period call before expiration

For two periods, the computation yields Call option

$$C = [c_u^2 p^2 + 2 c_{ud} p(1-p) + c_d^2 (1-p)^2] e^{-2r\Delta t}$$

$$\text{Where, } p = \frac{(e^{r\Delta t} - d)}{(u-d)}, \quad (1-p) = \frac{(u - e^{r\Delta t})}{(u-d)}$$

VIII. TRINOMIAL OPTION PRICING MODEL (TOPM) CALCULATION

Trinomial Option Pricing model was first introduced by Boyle (1986) [13, 14]. In this model stock price can either move up or down, or stay at the same price, which is determined by its volatility. Thus, TOPM has one more degree of freedom in terms of movement of its stock price compared to BOPM.

The magnitudes of the up move and down increments are given by

$$u = e^{(\sigma\sqrt{2\Delta t})}, \quad d = 1/u$$

The probability of up movement is given by

$$P_u = \left(\frac{e^{(\frac{1}{2}r\Delta t)} - e^{(-\sigma\sqrt{\frac{1}{2}\Delta t})}}{e^{(\sigma\sqrt{\frac{1}{2}\Delta t})} - e^{(-\sigma\sqrt{\frac{1}{2}\Delta t})}} \right)^2$$

while probability of down movement is

$$P_d = \left(\frac{e^{(\sigma\sqrt{\frac{1}{2}\Delta t})} - e^{(\frac{1}{2}r\Delta t)}}{e^{(\sigma\sqrt{\frac{1}{2}\Delta t})} - e^{(-\sigma\sqrt{\frac{1}{2}\Delta t})}} \right)^2$$



The probability of lateral move is given by

$$P_m = 1 - P_u - P_d$$

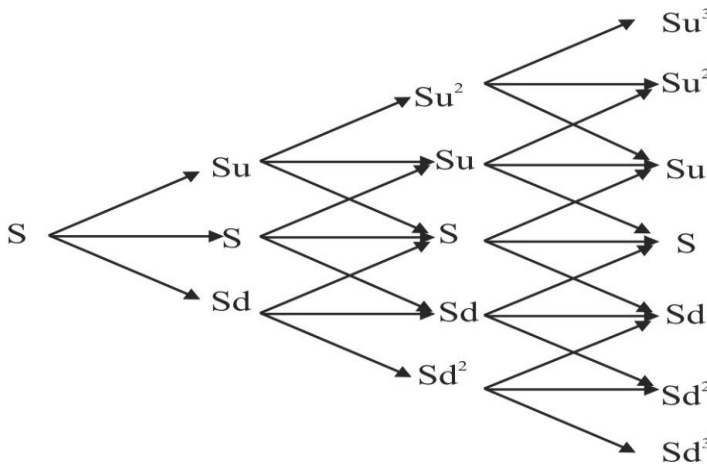

Fig1. 6 stock price with multi periods for trinomial option price

At node (i,j), the value of an American call with strike price K is

$$C_{i,j} = \text{Max} \left\{ S_{i,j} - K, e^{-r\Delta t} [p_u C_{i,j+1} + p_m C_{i+1,j+1} + p_d C_{i+2,j+1}] \right\}$$

The value of European call is

$$C_{i,j} = e^{-r\Delta t} [p_u C_{i,j+1} + p_m C_{i+1,j+1} + p_d C_{i+2,j+1}]$$

IX. INTRADAY STATISTICAL ANALYSIS OF DIFFERENT STOCK DATA

It has been recently empirically investigated that on high frequency stock price data reveal the emergence of non-Gaussian behavior for intraday stock returns. It has been a challenging problem for physicist, economist and computer scientist to find out the true distribution of stock price change. Here we use the three empirical high frequency data viz. NASDAQ 100, S&P 500 and NYSE data. It has been examined and it is found that intraday stock returns are non-Gaussian.

X. AIM AND SCOPE OF ANALYSIS

The interesting find out in this chapter after it has been analyzed from the three empirical data sets, that the price fluctuation of stock and its volatility distribution are well captured by lognormal distribution. But stock returns distributions are not characterized by the well-known Gaussian distribution. So there is deep underlying mechanism is needed to analyze the non-Gaussian behavior of intraday high frequency stock returns.

XI. REFERENCE

[1] J. Michael Steele, "Stochastic Calculus and Financial Applications", Springer-Verlag New York, (2001). John Hull and Alan White, Pricing Interest-Rate-Derivative Securities, The Review of Financial Studies, Volume 3 (4), pp. 573-592 (1990).

[2] E. Barucci, L. Landi and U. Cherubini, "Computational Finance", IEEE Computational Science & Engineering, 1996, pp.66-80.

[3] M. Baxter and A. Rennie, "Financial Calculus", Cambridge University Press, 1996.

[4] M. G. Hilgers, "Computational Finance" IEEE POTENTIALS, 2000, pp.8-10.

[5] J. Michael Steele, Stochastic Calculus and Financial Applications, Springer-Verlag New York, (2001).

[6] Y. Dauhlyuu, "Financial Engineering and Computation", Principles, Mathematics, Algorithms, Cambridge University pub., 2004.

[7] P. Glasserman, "Monte Carlo Methods in Financial Engineering", Springer-2004.

[8] C. W. Gardiner, "Handbook of Stochastic Methods", 3rd edition, Springer, 2004.

[9] R. U. Seydel Tools for Computational Finance, Springer, 2006.

[10] F. D. Rouah and G. VAINBERG Option pricing model & volatility, Wiley, 2007.

[11] Y. Kuen Kwok, "Mathematical Models of Financial Derivatives", 2nd edition, Springer, 2008.

[12] An Application of the Finite Difference Method and Control Variate Technique in the American Options Pricing Li Xing; Industrial Mechatronics and Automation (ICIMA), 2010 2nd International Conference.

[13] Monte Carlo & Quasi-Monte Carlo approach in option pricing; Maasar, M.A.; Nordin, N.A.M.; Anthonyrajah, M.; Zainodin, W.M.W.; Yamin, A.M. Humanities, Science and Engineering Research (SHUSER), 2012 IEEE Symposium.

[14] A Pragmatical Option Pricing Method Combining Black-Scholes Formula, Time Series Analysis and Artificial Neural Network; Kai Liu; Xiao Wang Computational Intelligence and Security (CIS), 2013 9th International Conference.