



PERFORMANCE EVALUATION OF INTERPOLATION FACTOR IN RRC FILTER FOR MRC SCHEME IN WCDMA SYSTEM

Rajkumar Gupta
Assistant Professor,
Amity University Rajasthan

Amit Chaurasia
Assistant Professor,
Amity University Rajasthan

Abstract— The performance of WCDMA is degraded with various factors such as interference, fading and scattering. This paper investigates the effect of interpolation factor in root raised cosine filter for wideband code division multiple access and bit error rate performance is analyzed with single input single output antenna system and single input multiple outputs antenna system using maximum ratio combining diversity technique by varying interpolation factor for quadrature phase shift keying and binary phase shift keying.

Keywords— WCDMA, root raised cosine filter, Interpolation factor, Antenna diversity, Maximum ratio combining.

I. INTRODUCTION

Wireless communication is the fastest growth period in the history of communication technologies. The 3rd generation partnership project (3GPP) and 3rd generation partnership project two (3GPP2) had developed the wideband code-division multiple access (WCDMA) technologies and CDMA2000 respectively [1]. WCDMA is considered to be wideband technologies based on the direct sequence spread spectrum transmission scheme, where user information bits are spread over a wide bandwidth by multiplying the user data with quasi-random bits called chips derived from CDMA spreading codes. In order to support very high bit rates (upto 2 Mbps), the use of a variable spreading factor and multicode connection is supported. The chip rate 3.84 Mcps leads a carrier bandwidth of 5MHz [2]. When a signal is transmitted from source to destination through the channel, there are some factors which degrade the performance of signal and these degradation factors are path loss, noise, fading and interference. One of the most powerful techniques to mitigate the effects of fading is to use diversity combining of independently fading signal paths. The concept behind diversity is: if one signal path undergoes a deep fade at a particular point of time, another independent path may have a strong signal [3]. Here receiver is provided with multiple copies of the same information signal which are transmitted over two or more real or virtual communication channels.

Hemalatha et.al [4] analyzed diversity in CDMA based broadband wireless system and found that the diversity CDMA system with multiple antennas at the transmitter and receiver results in the improvement in SNR and reduction in the multipath fading and interference. In communication system pulse shaping filter is used to generating band limited channels and reducing inter symbol interference (ISI) arising from multi path signal reflections [5]. The work in the present paper analyzed the performance of SISO and SIMO using MRC technique by varying the interpolation factor (M) of root raised cosine filter in WCDMA system.

The next section presents the square root raised cosine filter. The Section III describes the maximum ratio combining (MRC) diversity scheme. The simulation methodology describes in section IV. The simulation results and discussion is presented in the Section V. The last section concludes the paper and presents the future work.

II. SQUARE ROOT RAISED COSINE FILTER

In a digital communication system, digital information can be sent on a carrier through changes in its fundamental characteristics such as: phase, frequency, and amplitude. In a physical channel, these transitions can be smoothed, depending on the filters implemented in transmission. In fact, the use of a filter plays an important part in a communications channel because it is effective at eliminating spectral leakage, reducing channel width and eliminating interference from adjacent symbols. Different raised cosine filters are used in modern communication system. In this paper square root raised cosine filter are used [6]. The square root raised cosine, a variant of raised cosine pulse is used in the modern communication system whose frequency response is expressed as a square root of $F(w)$ in frequency domain or square root of $f(t)$ in time domain. The ideal root raised cosine filter, frequency response consists of unity gain at low frequencies and total attenuation at the high frequencies, the square root of raised cosine function in the middle. The width of the middle frequencies is defined by roll off factor constant α . Group



delay of filter is defined by initial response and its peak response. The group delay influences the size of output as well as order of filter. For minimizing the filter complexity, filter length or number of taps should be minimum as far as possible. Delay should be minimum for reducing the filter complexity. There is tradeoff between group delay (D) and interpolation factor (M) for better performance of pulse shaping filter for WCDMA based wireless communication system. So interpolation factor should be increased for minimizing the filter complexity.

$$N = D * M \tag{1}$$

N= filter taps
 D= group delay
 M= interpolation factor

The spectrum of square root raised cosine (SRRC) spectrum is given in following equation

$$SRRC(t) = \frac{\sin(\pi \frac{t}{T_c} (1-\alpha)) + 4\alpha \frac{t}{T_c} \cos(\pi \frac{t}{T_c} (1+\alpha))}{\pi \frac{t}{T_c} (1-(4\alpha \frac{t}{T_c})^2)} \tag{2}$$

Where T_c is the inverse of chip rate.
 α = Roll off factor.

III. MAXIMUM RATIO COMBINING

The diversity scheme is the solution to improve the performance of system in fading environment is to ensure that the information symbols pass through multiple signal paths, each of which fades independently, making sure that reliable communication is possible as long as one of the paths is strong and it can improve the performance over fading channels. Antenna diversity can be obtained by placing multiple antennas at the transmitter and/or the receiver [7]. Antenna diversity techniques use some combining methods such as selection combining, maximum ratio combining, and equal gain combining. The diversity schemes for single input single output (SISO) and single input multiple outputs (SIMO) are presented in Fig.1 and Fig.2.

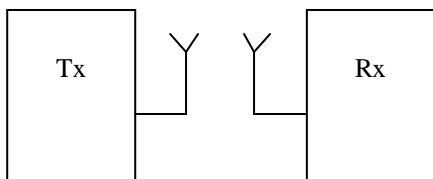

Fig.1 Single Input Single Output Antenna System (SISO)

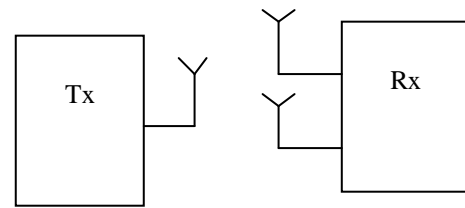

Fig.2 Single Input Multiple Outputs Antenna System (SIMO)

In maximum ratio combining (MRC) diversity scheme, all the branches are used simultaneously. Each of the branch signals is weighted with a gain factor which is proportional to its own SNR. After that, co-phasing and summing is done for adding up the weighted branch signals in phase [8]. Fig.3 shows the configuration for a two-branch diversity system. Both the branches are weighted by their respective signal-to-noise ratios and the branches are then co-phased prior to summing in order to insure that all branches are added in phase for maximum diversity gain. The summed signals are then used as the received signal and connected to the demodulator [9].

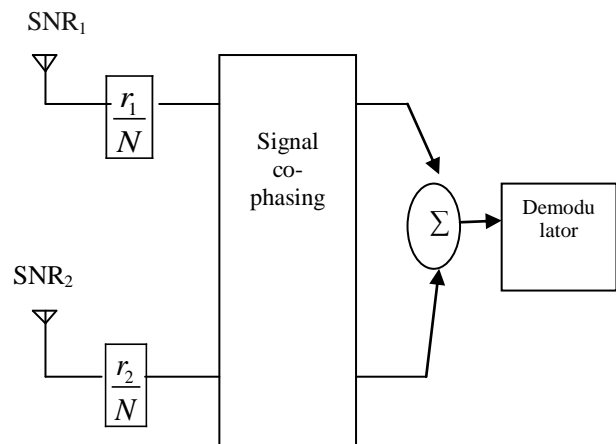

Fig.3 Block diagram of a two-branch maximal ratio combiner for equal noise powers in both branches

The inputs to the maximal ratio combiner (Fig.3) are both rayleigh distributed signals (with envelopes r_1 and r_2) with additive independent noise voltage sources n_1 and n_2 . n_1 and n_2 are zero mean white gaussian random variables with a variance of N ; the input voltage signal-to-noise ratios are

$$SNR_{r_{1,2}} = \frac{r_{1,2}^2}{N} \tag{3}$$



$$SNR_{V_{1,2}} = \sqrt{SNR_{P_{1,2}}} = \frac{r_{1,2}}{\sqrt{N}} \quad (4)$$

The amplitude of the signal of interest after MRC at a give time t_0 , $V_{S,M}(t_0)$, can be evaluated by multiplying the received signal enveloper r_1 and r_2 , at t_0 , by their instantaneous voltage to noise power ratios which when summed gives.

$$V_{S,M}(t_0) = r_1(t_0) \left(\frac{r_1(t_0)}{N} \right) + r_2(t_0) \left(\frac{r_2(t_0)}{N} \right) = \frac{r_1(t_0)^2 + r_2(t_0)^2}{N} \quad (5)$$

The noise component after MRC at t_0 , $V_{N,M}(t_0)$, is also multiplied by the gains in both branches and evaluates after co-phasing and branch addition to

$$V_{N,M}(t_0) = n_1 \left(\frac{r_1(t_0)}{N} \right) + n_2 \left(\frac{r_2(t_0)}{N} \right) = \frac{n_1 r_1(t_0) + n_2 r_2(t_0)}{N} \quad (6)$$

The noise power is given by

$$P_N = E[n_x^2] = \int_{-\infty}^{\infty} n_x^2 f_{N_x}(n_x) dn_x = N_x$$

$$P_{N,M}(t_0) = [V_{N,M}(t_0)]^2 = E \left[\frac{n_1^2 r_1(t_0)^2}{N^2} + \frac{2n_1 n_2 r_1(t_0) r_2(t_0)}{N^2} + \frac{n_2^2 r_2(t_0)^2}{N^2} \right]$$

$$P_{N,M}(t_0) = E \left[\frac{n_1^2 r_1(t_0)^2}{N^2} \right] + E \left[\frac{n_2^2 r_2(t_0)^2}{N^2} \right]$$

$$P_{N,M}(t_0) = \frac{r_1(t_0)^2}{N^2} E[n_1^2] + \frac{r_2(t_0)^2}{N^2} E[n_2^2] = \frac{r_1(t_0)^2 + r_2(t_0)^2}{N}$$

$$SNR_{P_M}(t_0) = \frac{r_1(t_0)^2 + r_2(t_0)^2}{N} = \frac{1}{N} (r_1(t_0)^2 + r_2(t_0)^2) \quad (7)$$

$$MGC \text{ Output (dB)} = SNR1 + SNR2$$

$$SNR_{P_M} \Big|_{N=1} = r_1^2 + r_2^2$$

$$SNR_{V_M} \Big|_{N=1} = \sqrt{r_1^2 + r_2^2} \quad (8)$$

IV. SIMULATION METHODOLOGY

The signal in WCDMA system is degraded with various factors such as path loss, noise, fading and interference. The

work in the present paper analyzed the performance of the maximum ratio combining (MRC) diversity scheme in WCDMA system to improve the signal quality. The simulated WCDMA system is designed in Matlab and the performance is analyzed for various modulations under varying network conditions. The bit error rate (BER) performance is evaluated with varying conditions of signal to noise (E_b/N_0). The block diagram of the simulated WCDMA system with proposed diversity scheme is presented in Fig.4.

V. SIMULATION RESULTS AND DISCUSSION

The performance of WCDMA system is analyzed for the maximum ratio combining diversity scheme with two antennas (nRx1 and nRx2) at the receiver under varying conditions of interpolation factor (M) in root raised cosine (RRC) filter. For simulating the WCDMA system in MATLAB, the group delay (D) and roll of factor (α) are fixed at D=5 and $\alpha=0.22$ respectively in RRC filter. The performance of the MRC antenna diversity scheme is performed at varying value 2 to 10 for interpolation factor (M) in RRC filter. The simulation analysis has been carried out for QPSK and BPSK modulation in two cases. Case 1 based on QPSK for MRC and case 2 based on BPSK for MRC.

Case-1 BER analysis of QPSK by varying interpolation factor (M)

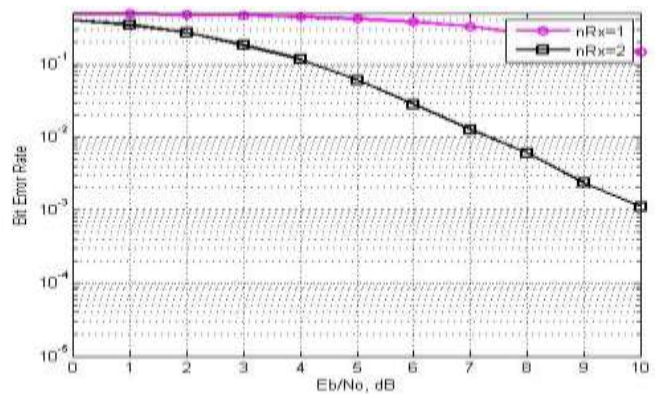

Fig 5 (M=2)



Fig 7 (M=7)

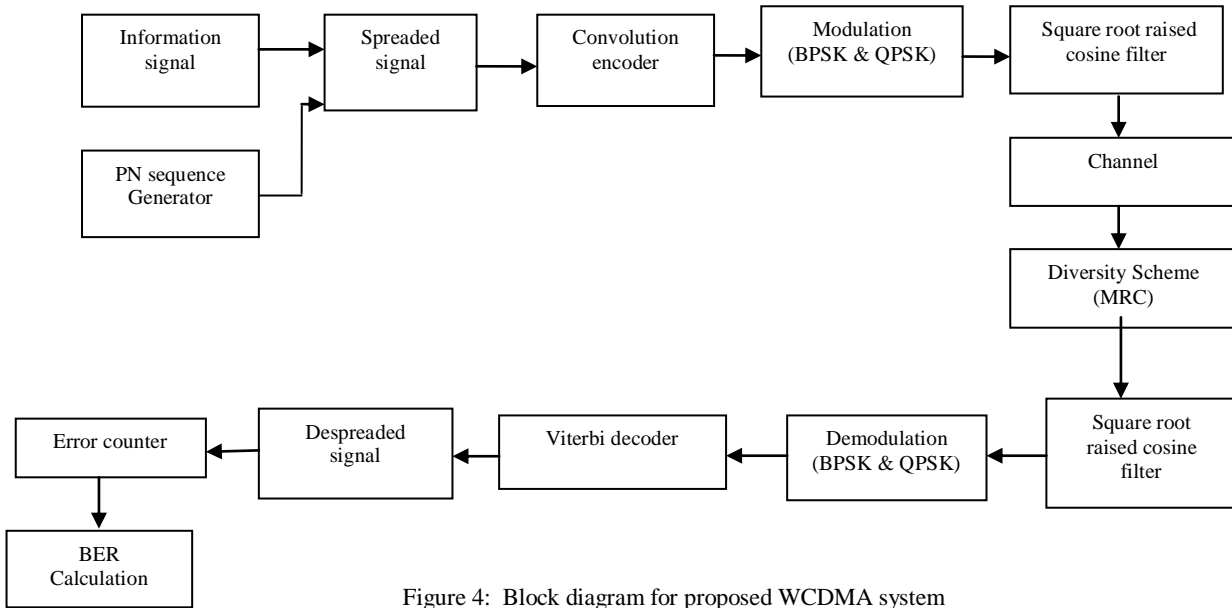

Figure 4: Block diagram for proposed WCDMA system

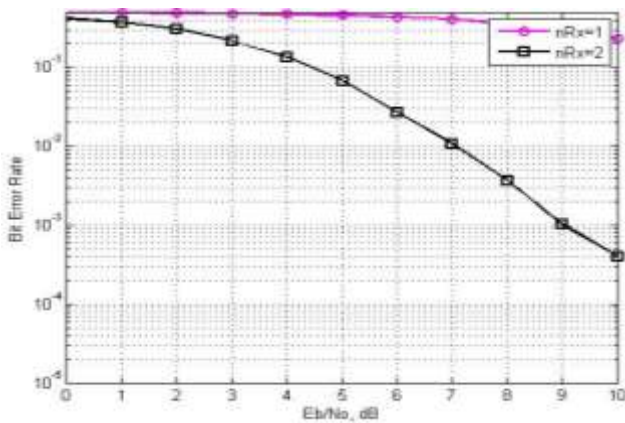

Fig 6 (M=5)

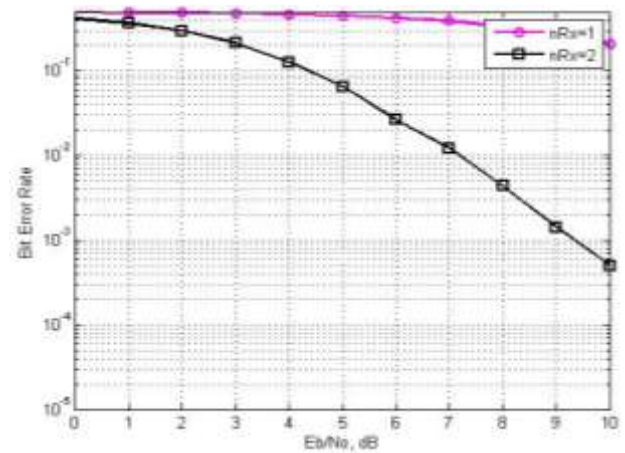
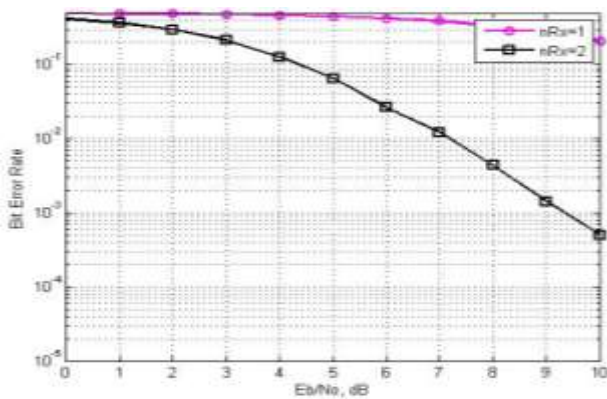

Fig 8 (M=10)



The BER v/s E_b/N_0 relationship for the WCDMA system with $nR_x = 1, 2$ is shown in Fig. 5 to Fig.8 with QPSK modulation scheme using MRC technique. As can be seen from Fig.5 in case of $nR_x = 2$, the BER obtained around 0.1159 at 4 dB and at higher value of E_b/N_0 , the achievable BER decreases around 0.0024 for 9 dB E_b/N_0 at $M=2$. At $M=5$ the BER obtained around 0.1053 at 4 dB and at higher value of E_b/N_0 , the achievable BER decreases around 0.0010 for 9 dB E_b/N_0 shown in Fig.6 for $nR_x = 2$. From Fig.7 the BER obtained around 0.1270 at 4 dB and at higher value of E_b/N_0 , the achievable BER decreases around 0.0014 for 9 dB E_b/N_0 at



M=7. At M=10 the BER obtained around 0.1413 at 4 dB and at higher value of E_b/N_0 , the achievable BER decreases around 0.0016 for 9 dB E_b/N_0 shown in Fig.8. It is observed from the simulation that the BER is gradually decrease when interpolation factor varying from 2 to 5. When interpolation factor varying from 5 to 10, BER is increased again. The optimum value of interpolation factor was found to be 5, at which both SISO and SIMO WCDMA system gave best performance.

Case-2 BER analysis of BPSK by varying interpolation factor (M)

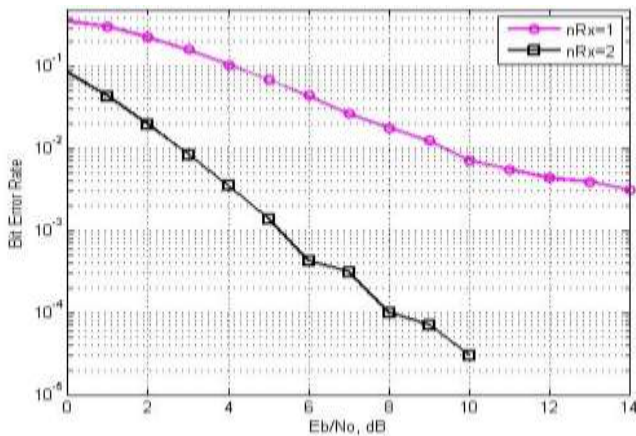

Fig 9 (M=2)

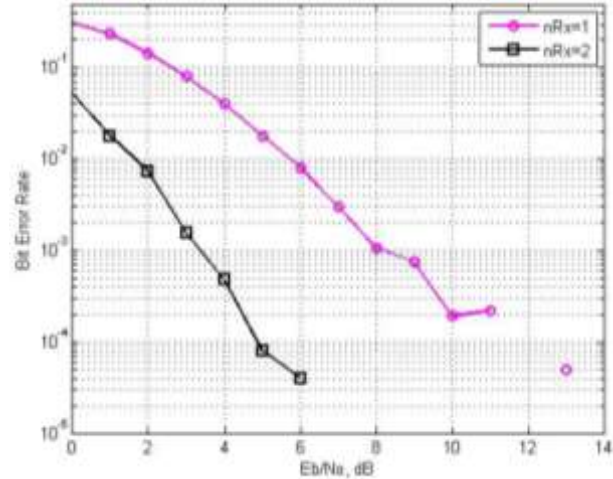

Fig 11 (M=7)

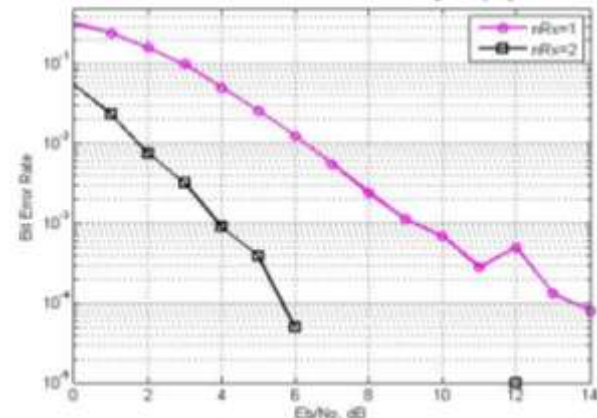

Fig 12 (M=10)

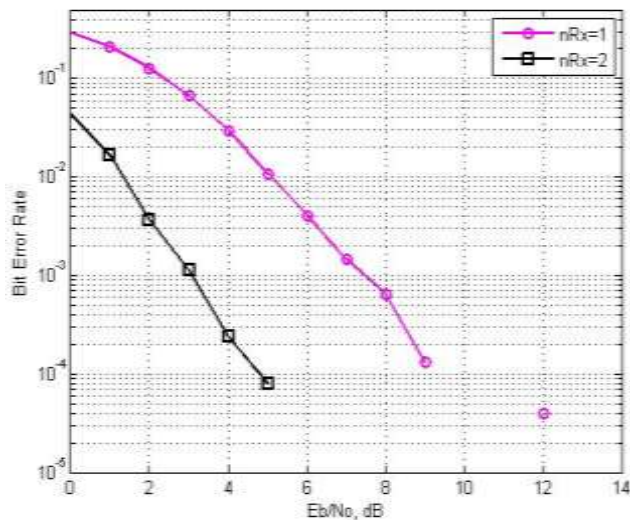

Fig 10 (M=5)

The BER v/s E_b/N_0 relationship for the WCDMA system with $nR_x=1, 2$ is shown in Fig. 9 to Fig.12 with BPSK modulation scheme using MRC technique. As can be seen from Fig.9 in case of $nR_x=2$, the BER obtained around 0.0035 at 4 dB and at higher value of E_b/N_0 , the achievable BER decreases around 0.0001 for 10 dB E_b/N_0 at M=2. At M=5 the BER obtained around 0.0002 at 4 dB and at higher value of E_b/N_0 , the achievable BER decreases around 0 for 10 dB E_b/N_0 shown in Fig.10 for $nR_x=2$. From Fig.11 the BER obtained around 0.0004 at 4 dB and at higher value of E_b/N_0 , the achievable BER decreases around 0 for 10 dB E_b/N_0 at M=7. At M=10 the BER obtained around 0.0009 at 4 dB and at higher value of E_b/N_0 , the achievable BER decreases around 0.0000 for 10 dB E_b/N_0 shown in Fig.12. It is observed from the simulation that the BER is gradually decrease when interpolation factor varying from 2 to 5. When interpolation factor varying from 5 to 10, BER is increased again. The optimum value of interpolation factor was found to be 5, at which both SISO and SIMO WCDMA system gave best performance.



VI. CONCLUSION AND FUTURE WORK

The work in this paper analysed the joint effect of maximum ratio combining diversity scheme along with root raised cosine filter to reduce the affect of inter symbol interference and inter-intra cell interference. For minimizing the filter complexity, filter length or number of taps should be minimum as far as possible. There is tradeoff between group delay and interpolation factor for better performance of pulse shaping filter for WCDMA based wireless communication system. So interpolation factor should be increased for minimizing the filter complexity and increases the BER performance for both SISO and SIMO WCDMA system. It was observed from the simulation result that the SIMO system gave better performance in comparison to the SISO system. Results also conclude that BPSK modulation technique is better compare to QPSK for SISO and SIMO. In future work the same analysis will be carried out for MIMO system and implement on FPGA.

- IEEE Wireless Communications and Networking Conference*, 2004, Atlanta, USA, Vol.2, pp 908-913, 2004.
- [9] Gordon S.L., "Principle of mobile communication," Kluwer academic, boston, 1996.

VII. REFERENCES

- [1] Olavarrieta L.D., "Wireless communications education: A Guide to Important Topics, *Microwave Review*, November, 2005.
- [2] Prasad R. and Ojanpera T., "An overview of CDMA evolution towards wideband CDMA," *IEEE communication survey*, Vol.1, pp.2-29, fourth quarter 1998.
- [3] Proakis J.G.: *Digital Communications*, McGraw-Hill, 1995.
- [4] Hemalata.M et.al, "Diversity analysis in CDMA based broadband wireless system ", *Research Journal of Applied Sciences, Engineering and Technology* 4(6): 660-663, 2012.
- [5] Kang A.S and Sharma V, "Analysis of Simulation parameters of pulse shaping FIR filter for WCDMA", *International Journal of Advancements in Technology*, ISSN 0976-4860, Vol. 1, No. 1, June 2010 .
- [6] Kang A. S. and Sharma V, "Study of Spectral Analysis of Filters in Cellular Communication Systems", in *Proceedings of IEEE International Conference on advance Computing Conference*, March 2009.
- [7] Sedani B.S;Kulkarni G.R.; "Implementation of quality based algorithm for Wimax simulation using SISO and MIMO techniques", *Global journal of researches in engineering*, Vol.10,no.4, pp. 106-112, 2010.
- [8] Zhou h. and Okamoto k., "Comparison of code combining and MRC diversity reception in mobile communications",